

ENERGY - FREE LIVESTOCK DRINKER INSTALLATION INSTRUCTIONS, WARRANTY INFORMATION, AND REPAIR PARTS LISTS

READ ALL DIRECTIONS CAREFULLY BEFORE BEGINNING INSTALLATION

FIRST OF ALL – PURCHASE AN ANTI-SEIZE COMPOUND (BY PERMATEX OR EQUIVALENT) AVAILABLE AT MOST AUTOMOTIVE SUPPLY STORES. USE ON THE MOUNTING LAG BOLTS AND USE ON YOUR VALVE COVER FASTENERS.

ALSO,

PURCHASE WEATHERPROOF CAULKING TO SEAL THE BASE OF THE DRINKER TO THE CONCRETE PAD.

ALSO,

OUR VALVE IS MOLDED WITH ABS RESIN. FOR THREAD SEALING, USE ONLY STANDARD TEFLON TAPE OR PLASTIC COMPATIBLE TEFLON SEALANT. DO NOT USE PIPE THREAD SEALANT (COMMONLY CALLED “PIPE DOPE”) OR SEALANT FORMULATED WITH PTFE.

SITE PREPARATION

EXHIBIT A

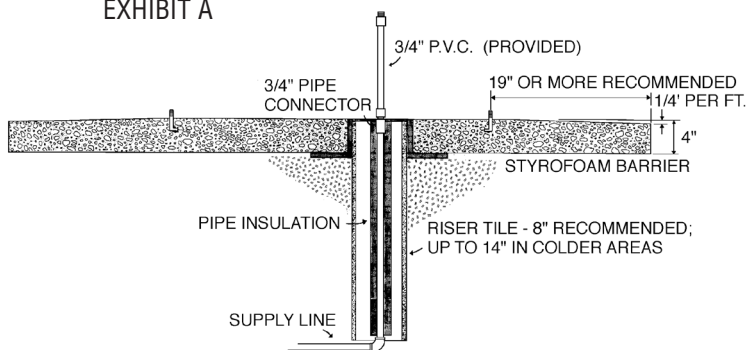

SUPPLY LINE - The supply line should be at least 3/4 inch (1.9 cm) diameter. However, the line should be sized to account for any pressure drop relating to distance. Water lines over 50 feet (15 meters) should be one inch (2.54 cm) or larger. An undersized supply line may cause insufficient water recovery capability. We provide a 3/4 inch adapter (Ref No. 18) to connect with your supply line. A very good connection is one with the fewest number of connections, fittings and the like. **OPTION 1:** So, you may want to consider extending a vertical PVC supply tube all the way from your horizontal underground supply line through the riser tile and through the drinker. The vertical supply tube needs to be long enough to extend 4 to 6 inches (10 to 15 cm) above the top of the drinker. **OPTION 2:** The second option is to use the supply line (Ref. No. 15) we provide with each drinker and glue (Ref. No. 18) standard adapter to the end of your supply line coming out of the ground. (NOTE: glue the Ref. No. 18 standard adapter and NOT the Ref. No. 13 adapter which is machined)

RISER TILE - The ideal size of riser tile depends on the installation, source of water and geography. If you are replacing an existing waterer and have had no supply line freezing problems and have been using no supplemental heat on your supply line, you can probably use your existing tile. For best protection, we recommend that a new riser tile of at least 8 inches (20.3 cm) diameter be installed. **INSTALLATION MUST BE MADE WITHOUT THE SUPPLY LINE TOUCHING THE RISER TILE AND THERE MUST BE NO DEBRIS OR DIRT IN THE RISER TILE. DO NOT STUFF YOUR RISER TILE WITH INSULATION AS IT CAN BECOME WATER LOGGED RESULTING IN FROST PENETRATION.** If the installation is north of Interstate 90 or if frost heaving is a problem in your area, use a flexible supply line, such as 3/4 inch (1.9 cm) braided vinyl tubing available at most plumbing supply outlets. If your water supply line is flexible and you are concerned that the flex may cause it to touch the riser tile, use a deep well submersible cable guard (a nylon plate that slips over the supply line and keeps it centered). Ask for a deep well submersible pump cable guard at your local plumbing supply outlet. Be sure to use the foam pipe insulation (provided) and make sure the insulation does not touch the riser tile as well. Where incoming ground water temperature is 50° F (10° C) or higher, most likely you can use an 8-10 inch (20-25 cm) diameter riser tile. If entering water is below 50° F (10° C), you should probably use a 10-14 inch (25-35 cm) diameter tile but consult a local expert.

MOUNTING PAD –The concrete pad should be about 4 inches (10.2 cm) thick. Surface area where drinker sits should be smooth and level to provide a good seal. From the edge of the drinker, the concrete should slope away from the drinker about 1/4 inch per foot. We suggest you pour a pad large enough for animals to comfortably stand on while drinking. The concrete underneath the drinker should be smooth but a rough broom finish provides a better finish for the concrete where the animals stand.



P.O. BOX 2000 • HOUGHTON, IOWA 52631 • USA
TELEPHONE 319-469-4141 FAX 319-469-4402

COPYRIGHT © 2026
ALL RIGHTS RESERVED

WHEN ORDERING PARTS

- (1) Show NAME and MODEL NUMBER: Example - WPM80
- (2) Show PART NUMBER and FULL DESCRIPTION
of part: Example: WPM7503 Cover

HOW TO ORDER PARTS

Repair parts may be ordered
from your dealer.

website: www.hawkeysteel.com email: sales@hawkeysteel.com

ISHWPM
REV. 1.8
PRINTED IN USA

MOUNTING THE DRINKER

WE RECOMMEND THE USE OF TEFLON TAPE OR COMPATIBLE PLUMBERS' PASTE ON ALL CONNECTIONS

EXHIBIT B

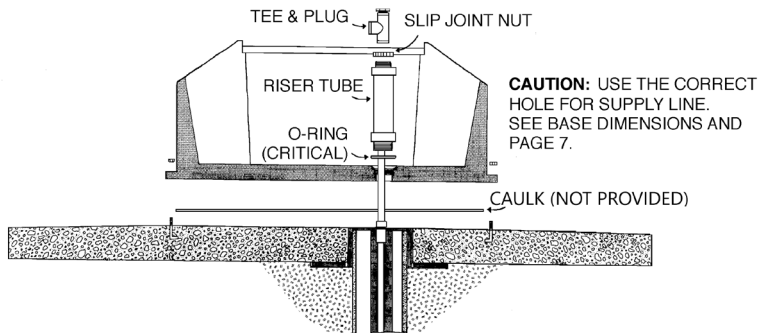

MOUNTING DRINKER - Review Exhibit B.

1. Slide pipe insulation down over supply tube making it even with the top of the riser tile. Hold in place at the top with tywrap provided.
2. Caulk the reservoir bottom about 1 inch in from the sides and inside the anchor slots. There should be NO GAP between reservoir and the concrete.
3. Set reservoir over supply tube keeping supply tube centered in the tile. Anchor drinker at this time.
4. Slip riser tube over supply tube and tighten into reservoir base. Make sure O-ring is in place on the riser tube.
Review Exhibit C.
5. Mark supply tube so that 1/2 inch (1.27 cm) extends above the top of riser tube and cut supply tube at mark. Removing riser tube before cutting supply tube may make this step easier. Glue MACHINED 3/4 inch (1.9 cm) MPT to PVC adapter (Ref. No. 13) to top of supply tube. Replace and tighten riser tube if you have removed it.
6. Tighten slip joint nut, (Ref. No. 14) at top of riser tube, against the biggest diameter of the 3/4 inch (1.9 cm) MPT to PVC adapter (Ref. No. 13) on the supply tube. This should be centered on the smooth surface.
7. Tighten 3/4 inch (1.9 cm) Ref. No. 12 tee on supply tube with the pipe plug up.
8. Lag drinker to pad. USE AN ANTI-SEIZE COMPOUND ON THE LAG BOLT THREADS AND NUTS.

INSTALLING THE VALVE - Review Exhibit D. The valve comes assembled. Install the valve base into Ref. No 12 3/4" x 3/4" x 3/4" tee. You can tighten the base to the tee with a 1" box end wrench. Use teflon tape or plumbing paste. Assemble Ref. No. 8 float arm to Ref. No. 9 float using two Ref. No. 7 adjusting screws. Adjust the float so water fills the reservoir approximately 1 inch (2.54 cm) from the overflow of the drink opening. There is a "FILL TO THE LINE" mark in each drink opening. Refer to Exhibit E on page 3 for valve repair parts. **NOTE: OUR VALVE IS MOLDED WITH ABS RESIN. FOR THREAD SEALING, USE ONLY STANDARD TEFLON TAPE OR PLASTIC COMPATIBLE TEFLON SEALANT. DO NOT USE PIPE THREAD SEALANT (COMMONLY CALLED "PIPE DOPE") OR SEALANT FORMULATED WITH PTFE.**

COMPLETE INSTALLATION - If necessary, mount flaps to the cover using the 13 inch (33 cm) hinge rod and OF121 washer on each end of the rod and the OF78 cotter pin on each flap. On some models, the flaps are already attached. Mount the cover assembly to the base. Use the OF448 hex machine screws and OF127SS washer to mount the cover assembly to the base. **LIGHTLY SNUG THE SCREWS ONLY. DO NOT OVERTIGHTEN. WE HIGHLY RECOMMEND USE OF ANTI-SEIZE COMPOUND (BY PERMATEX OR EQUIVALENT) ON THE OF448 HEX MACHINE SCREWS.**

EXHIBIT C

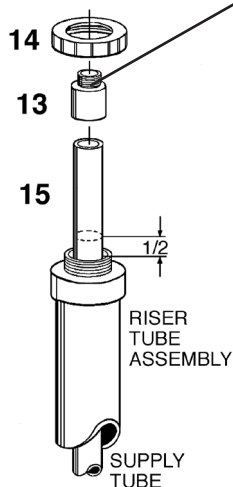

NOTE: MAKE SURE MACHINED 3/4 INCH MPT TO PVC ADAPTER IS UP. THE NON-MACHINED STANDARD ADAPTER IS GLUED TO THE BOTTOM END OF THE SUPPLY TUBE. ALLOW SUPPLY TUBE TO EXTEND 1/2 INCH (1.27 cm) BEYOND THE RISER TUBE ASSEMBLY.

EXHIBIT D

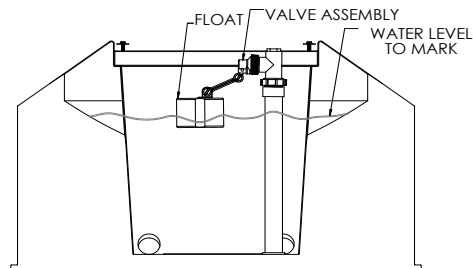

Use of an anti-seize compound will extend the life of the inserts used to hold your valve cover in place. Should your inserts become non-useable, order the following replacement parts.

OF406-Insert, 3/8"-16
Internal Thread, Zn

OF445-3/8"-16 x 1 1/2" Hex Head Cap
Screw, SS

MANAGEMENT SUGGESTIONS:

Locate drinker in a sheltered place if possible. Install unit 25 feet (7.5 meters) or so from feed sources to reduce the amount of feed dropped into the tank. If making a new installation, a stop and waste valve should be considered for a shut off valve. Water will probably enter the unit at 44°F to 56°F (6.7°C to 13.3°C) depending on your geographic area. **ALSO, NOTE PARAGRAPH 7 BELOW CONCERNING POND WATER OR OTHER COLD SOURCE WATER.** Water inside the unit will lose 10-12°F (5°-6°C) per day with no usage (when windchill temperature is 0°F (-17°C)). When you see ice, the drinker is telling you it's running out of energy. To avoid icing, follow these tips.

1. MAKE SURE YOU HAVE AN AIRTIGHT AND WATERTIGHT CONNECTION BETWEEN THE MOUNTING PAD AND DRINKER BASE.
2. MAKE SURE YOUR RISER TILE IS FLUSH WITH THE TOP OF THE PLATFORM.
3. MAKE SURE THERE IS NO OTHER SOURCE OF WATER IN THE FEEDLOT - ABSOLUTELY NONE. BE SURE THERE ARE NO PONDS, STREAMS, STOCK TANKS OR ANY ALTERNATIVE SOURCE OF WATER OTHER THAN YOUR ENERGY FREE DRINKER.
4. MAINTAIN THE WATER LEVEL AT 1 INCH (2.54 cm) BELOW THE TOP OF THE DRINK OPENING. In the event of water supply failure, cover the drinker so animals cannot drink from it. If water has already dropped below the bottom end of the baffle in the drinking opening, add water to within 1 inch (2.54 cm) from drinker opening.
5. Under the most extreme conditions and with little drinking activity, you may see ice in the drinker openings. Should this occur, simply break the ice, dip out a couple of gallons (8 liters) and listen for the valve to open. If supply line freezes, remove plug at top of supply line and use rod to dislodge any ice or pour hot water down supply line. You can also use rock salt.
6. Check drinker flaps daily. Remove any ice from drinker opening.
7. PLEASE NOTE: As we say on our literature, IF ENTERING WATER IS LESS THAN ABOUT 40°F (4.4°C), SUCH AS WATER FROM A POND, MOUNTAIN SPRING WATER OR COLDER GROUND WATER, YOU MAY EXPERIENCE ICING IN THE DRINKER OPENINGS. Most pond water is less than 40°F (4.4°C) (as low as 34°F (1.1°C)) after the pond is iced over. We do not guarantee results where the entering water is less than 40°F (4.4°C). Drinkers can work in such cases. Chances for success increase if the drinker is sheltered and if you have an abundance of drinking activity (50 head +). Most likely, the valve will stay open but - under severe conditions - you may have to remove ice from your drinker openings daily. Severe conditions are where windchills or actual temperatures are consistently below about 10°F (-12°C) day and night. **ALSO, please note that this paragraph applies primarily to our units with less than 15 gallons (56.8 liters) capacity; i.e. WPM10/MPM10/WPM14. Our 20 gallon (75.7 liter) and larger capacity units tend to work better with colder incoming water. However, even with these, you may still experience occasional icing. Follow these additional tips for ease of management.**
8. If drinker is not being used for short periods in the winter, dip out or drain 3-5 gallons (11-19 liters) each day to prevent eventual freezing.
9. If unit is not being used for extended periods, drain unit completely, shut off the water and drain water line below frost level.
10. If you experience any difficulty in getting animals to drink, invert flaps for a few days. See our brochure.
11. When tank needs to be cleaned, stir up solids so they are in suspension. Reach through drinker openings and remove plugs (or push plugs through outside openings). The valve will activate giving a flushing action.
12. When servicing during cold weather, use artificial inseminator's plastic sleeve to keep hands and clothing dry.
13. If drinker is used inside and if animals drink continuously, you may not need to use flaps. Before removing, however, tie them open or invert to see if any icing occurs.
14. If ice buildup occurs from animals slobbering around the opening, lower the water level slightly (not more than 1 inch).

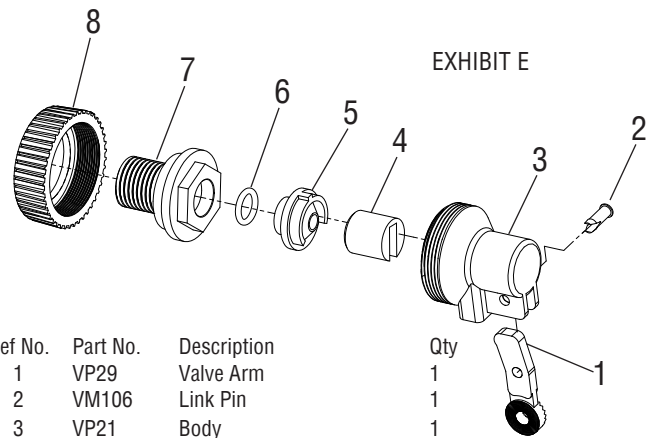

Ref No.	Part No.	Description	Qty
1	VP29	Valve Arm	1
2	VM106	Link Pin	1
3	VP21	Body	1
4	VP28	Plunger	1
5	VP26	1/4 Orifice	1
6	VP112	O-Ring	1
7	VP13	3/4 NPT Base, Poly	1
8	VP15	Assembly Nut	1

-VM117 Float, VA6/VA4 Float Arm, and VP115 Adjusting Screws are not included with VP224 Valve.
 - VP28 Plunger comes with a rubber insert. The rubber insert cannot be ordered separate.

To maintain float height under high water pressure, consider adding a star washer (not included) between the valve arm and the float arm.

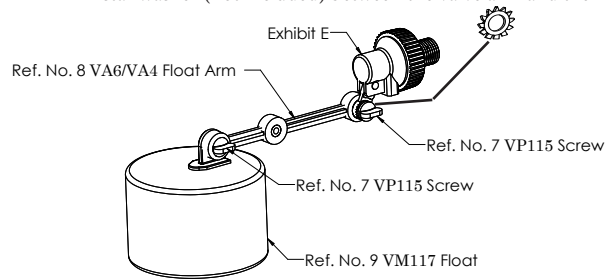

VP224 VALVE FLOW RATES
 With VP20 1/4" Orifice

PSI	Gallons Per Minute
25	4.2
40	7.5
60	9.2
80	9.7

If you have high water pressure and you believe our Valve Model VP224 is not properly shutting off, there are two possible options. Consider installing a pressure regulator or replace VP26 1/4" orifice with VP24 1/8" orifice. You do not need to change the valve - just change the orifice. Water flow with VP24 1/8" orifice compared with VP 26 1/4" orifice will be reduced by half or more. This flow rate may be sufficient for the number of animals using one drinker.

WARRANTY

From the date of purchase, all components, of our energy free drinkers except our valve parts, are covered by a five year warranty for all defects in material and workmanship. After the 5 year warranty period, all components, except valve parts are covered by an additional 11 year pro-rated warranty. Valve parts are warranted for 18 months. Warranty is limited to the replacement of components. Warranty does not cover animal chewed components where stainless steel guards are not used. All provisions stated on the back of Hawkeye Steel Products, Inc.'s invoice apply and Hawkeye Steel Products, Inc. assumes no contingent liabilities.

Assembly Schematic, Repair Parts List, Base Dimensions

Ref. No.	Part No.	Description	Qty
1	WPM103	Cover, Blue	1
1	MPM103	Cover, Red	1
2	OF448	1/4-20 x 1 1/2 Hex Head Screw, SS	4
3	OF127SS	1.10" OD x .280" ID Washer, SS, 1"	4
4	OF351	5/16" ID x 3/4" OD Washer, SS - 5/16"	4
5	OF78SS	1/8" x 3/4" Cotter Pin, SS	2
6	WPM107	.311" x 13.187" Lid Hinge Rod, Zinc	2
7	VP115	Adjusting Screw	2
8	VA6	Float Arm, 6" Plastic	1
9	VM117	Poly Float, Plastic	1
10	VP224	Valve Assembly, 1/4" Orifice	1
11	OP223	3/4" Schedule 40 Plug, PVC	1
12	OP114	3/4" x 3/4" x 3/4" Schedule 80 Tee, PVC	1
13	OP116	3/4" Schedule 40 Male Adapter, Machined, PVC	1
14	OP117SJM	1 1/2" Slip Joint Nut	1
15	WPM112	3/4" PVC Pipe x 14-3/4" (Supply Tube)	1
16	WPM113	Riser Tube Assembly, 10"	1
17	OP119	1 3/4" ID x 2 1/8" OD "O" Ring, Rubber	1
18	OP116P	3/4" Schedule 40 Male Adapter, Standard, PVC	1
19	OP314	#11.5 Rubber Stopper	2
20	WPM100	Base Reservoir 10 Gal., Blue	1
20	MPM100	Base Reservoir 10 Gal., Red	1
21	OP210	1 1/2" NPT Pipe Plug, PVC	1
22	WT208	Foam Pipe Insulation 36"	1
23	OP93	10 1/2" Tywrap	1
24	WPM205	Flap for WPM10A, Sheep, Blue	2
24	MPM205	Flap for MPM10A, Sheep, Red	2
25	WPM104	Flap for WPM10, Hog, Blue, Plastic Only	2
25	MPM104	Flap for MPM10, Hog, Red, Plastic Only	2
26	WPM124	Inner Lip Guard (For WPM10/MPM10)	2
27	WPM125	Outer Lip Guard (For WPM10/MPM10)	2
28	OF476	10 x 5/8" Tapping Screw, SS	12
29	WPM108	Hardware Bag	

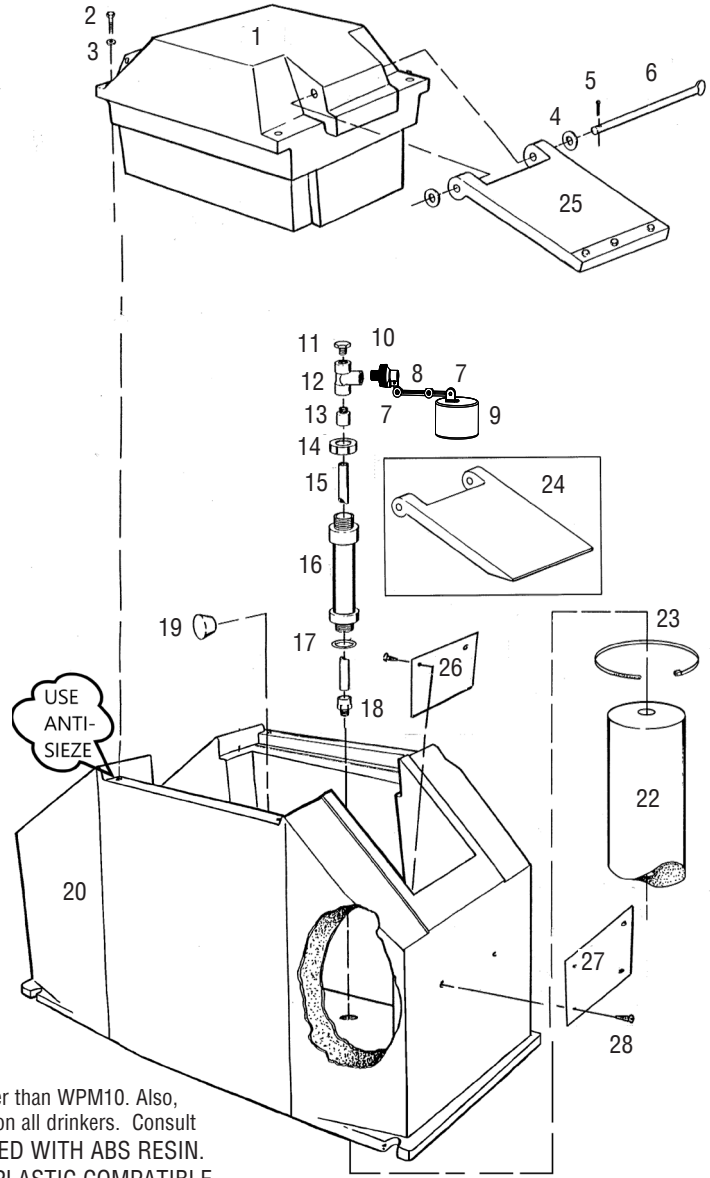

NOTE: Base dimensions of models are not the same. For example: WPM20 is longer than WPM10. Also, the threaded access for the riser tube assembly is not in the same location on all drinkers. Consult each diagram. Do not assume models are similar. OUR VALVE IS MOLDED WITH ABS RESIN. FOR THREAD SEALING, USE ONLY STANDARD TEFLON TAPE OR PLASTIC COMPATIBLE TEFLON SEALANT. DO NOT USE PIPE THREAD SEALANT (COMMONLY CALLED "PIPE DOPE") OR SEALANT FORMULATED WITH PTFE.

Top Down View
Base Dimensions in Inches (Centimeters)

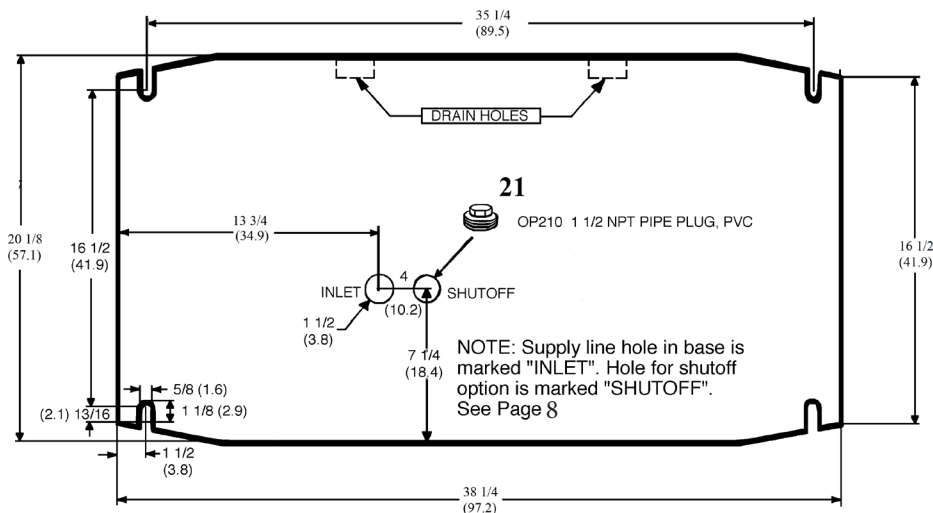

The dimensions shown are as accurate as we can show them. However, the molding process is affected by the temperature and humidity conditions on the day the part is molded. As the material cools, there can be uneven and unpredictable shrink which can affect the dimensions shown. It is usually best to wait until you have the actual drinker you are going to install before installing all four mounting studs.

Assembly Schematic, Repair Parts List, Base Dimensions

Models WPM14 & WPM14A
Description

Ref. No.	Part No.	Description	Qty
1	WPM1403	Cover, Blue for WPM14	1
2	OF448	1/4"-20 x 1 1/2" Indented Hex Head Screw, SS	4
3	OF127SS	1.10" OD x .280" ID Washer, SS, 1"	4
4	OF351	5/16" ID x 3/4" OD Washer, SS - 5/16"	8
5	OF78SS	1/8" x 3/4" Cotter Pin, SS	4
6	WPM107	.311" x 13.187" Lid Hinge Rod, Zinc	4
7	VP115	Adjusting Screw, Plastic	2
8	VA4	Float Arm, 4" Plastic	1
9	VA117	Poly Float	1
10	VP224	Valve Assembly, 1/4 Orifice	1
11	OP223	3/4" Schedule 40 Plug, PVC	1
12	OP114	3/4" x 3/4" x 3/4" Schedule 80 Tee, PVC	1
13	OP116	3/4" Schedule 40 Male Adapter, Machined, PVC	1
14	OP117SJM	1 1/4" Slip Joint Nut	1
15	WPM112	3/4" PVC Pipe x 14-3/4" (Supply Tube)	1
16	WPM1407	Riser Tube Assembly, 9"	1
17	OP119	1 3/4" ID x 2 1/8" OD "O" Ring, Rubber	1
18	OP116P	3/4" Schedule 40 Male Adapter, Standard, PVC	1
19	OP314	#11.5 Rubber Stopper	2
20	WPM1400	Base Reservoir 14 Gal., Blue	1
21	OP210	1 1/2" NPT Pipe Plug, PVC	1
22	WT208	Foam Pipe Insulation 36"	1
23	OP93	10 1/2" Tywrap	1
24	WPM205	Flap for WPM14A, Sheep, Blue	4
25	WPM104	Flap for WPM14, Hog, Blue, Plastic Only	4
26	WPM124	Inner Lip Guard (For WPM14) *	4
27	WPM125	Outer Lip Guard (For WPM14) *	4
28	OF476	10" x 5/8" Tapping Screw, SS	24

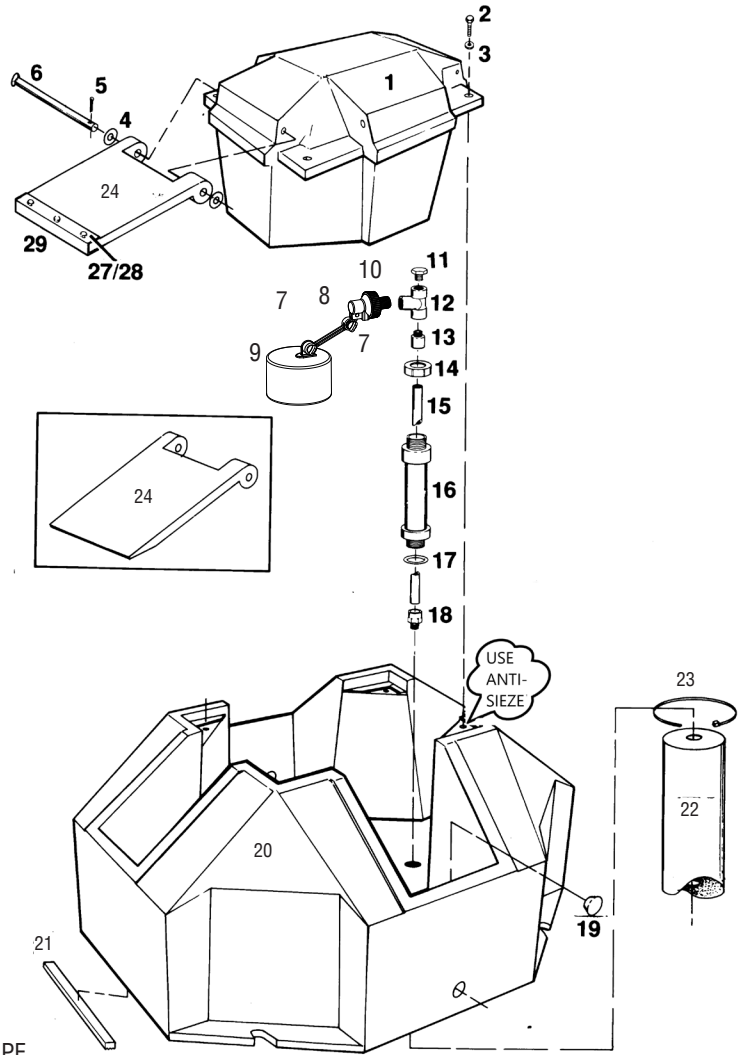

*Not shown: See Ref. Nos. 26 and 27 on page 4.

OUR VALVE IS MOLDED WITH ABS RESIN. FOR THREAD SEALING, USE ONLY STANDARD TEFLON TAPE OR PLASTIC COMPATIBLE TEFLON SEALANT. DO NOT USE PIPE THREAD SEALANT (COMMONLY CALLED "PIPE DOPE") OR SEALANT FORMULATED WITH PTFE.

Top Down View
Base Dimensions in Inches (Centimeters)

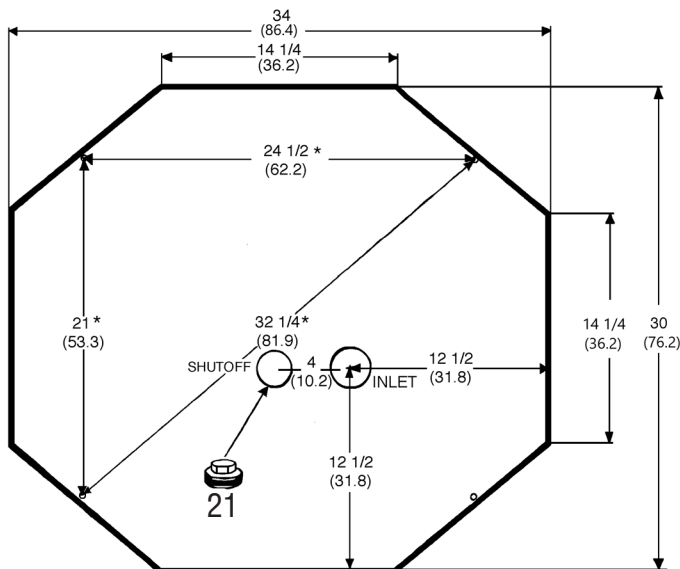

* Distance from center of notch to center of notch.

NOTE: Supply line hole in base is marked "INLET". Hole for shutoff option is marked "SHUTOFF". See Page 7.8

The dimensions shown are as accurate as we can show them. However, the molding process is affected by the temperature and humidity conditions on the day the part is molded. As the material cools, there can be uneven and unpredictable shrink which can affect the dimensions shown. It is usually best to wait until you have the actual drinker you are going to install before installing all four mounting studs.

Assembly Schematic, Repair Parts List, Base Dimensions

Model WPM16

Ref. No.	Part No.	Description	Qty
1	WPM16103	Cover, Single Sleeve, Blue	1
2	OF448	1/4"-20x1 1/2" Indented Hex head Machine Screw, SS	4
3	OF127SS	1.10" OD x .280" ID Washer, SS, 1"	4
4	OF351	5/16" ID x 3/4" OD Washer, SS - 5/16"	2
5	OF78SS	1/8" x 3/4" Cotter Pin, SS	1
6	WPM107	.311 x 13.187 Lid Hinge Rod, Zinc	1
7	VP115	Adjusting Screw, Plastic	2
8	VA6	Float Arm, 6" Plastic	1
9	VM117	Poly Float	1
10	VP224	Valve Assembly, 1/4 Orifice	1
11	OP223	3/4" Schedule 40 Plug, PVC	1
12	OP114	3/4" x 3/4" x 3/4" Schedule 80 Tee, PVC	1
13	OP116	3/4" Schedule 40 Male Adapter, Machined, PVC	1
14	OP117SJM	1 1/4" Slip Joint Nut	1
15	WPM212	3/4" PVC Pipe x 19-1/4" (Supply Tube)	1
16	WPM1613	Riser Tube Assembly, 16 3/4"	1
17	OP119	1 3/4" ID x 2 1/8" OD "O" Ring, Rubber	1
18	OP116P	3/4" Schedule 40 Male Adapter, SStandard, PVC	1
19	OP314	#11.5 Rubber Stopper	2
20	WPM1600	Base Reservoir 16 Gal., 1-Drink	1
21	OP210	1 1/2" NPT Pipe Plug, PVC	1
22	WT208	Foam Pipe Insulation 36"	1
23	OP93	10 1/2" Tywrap	1
24	MPM205	Flap, Blue, Cattle	1
	WPM1608	Hardware Bag	1

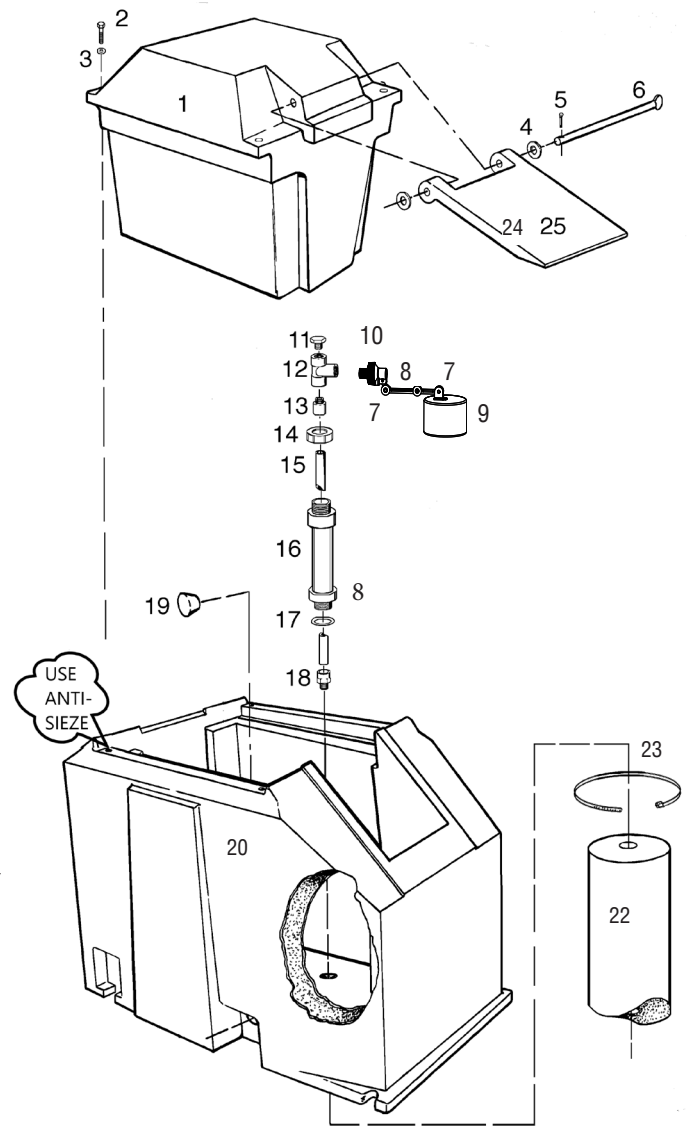

OUR VALVE IS MOLDED WITH ABS RESIN. FOR THREAD SEALING, USE ONLY STANDARD TEFLON TAPE OR PLASTIC COMPATIBLE TEFLON SEALANT. DO NOT USE PIPE THREAD SEALANT (COMMONLY CALLED "PIPE DOPE") OR SEALANT FORMULATED WITH PTFE.

Top Down View
Base Dimensions in Inches (Centimeters)

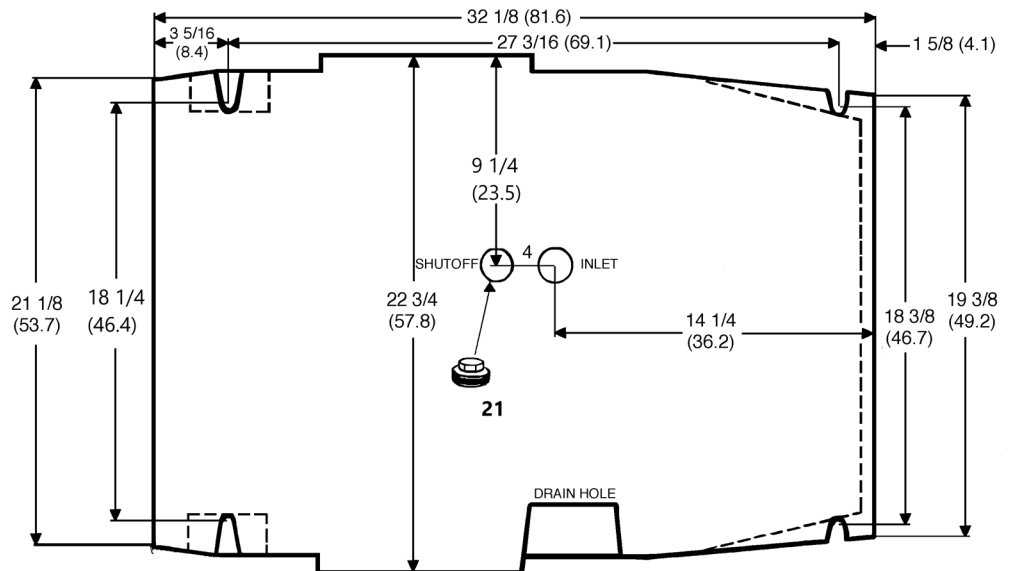

NOTE: Supply line hole in base is marked "INLET". Hole for shutoff option is marked "SHUTOFF". See Page 7.8

The dimensions shown are as accurate as we can show them. However, the molding process is affected by the temperature and humidity conditions on the day the part is molded. As the material cools, there can be uneven and unpredictable shrink which can affect the dimensions shown. It is usually best to wait until you have the actual drinker you are going to install before installing all four mounting studs.

Assembly Schematic, Repair Parts List, Base Dimensions

Model WPM20 and MPM20

Ref. No.	Part No.	Description	Qty
1	WPM103	Cover, Blue	1
1	MPM103	Cover, Red	1
2	OF448	1/4"-20 x 1 1/2" Indented Hex head Machine Screw, SS	4
3	OF127SS	1.10" OD x .280" ID Washer, SS, 1"	4
4	OF351	5/16" ID x 3/4" OD Washer, SS - 5/16"	4
5	OF78SS	1/8" x 3/4" Cotter Pin, SS	2
6	WPM107	.311 x 13.187 Lid Hinge Rod, Zinc	2
7	VP115	Adjusting Screw, Plastic	2
8	VA6	Float Arm, 6" Plastic	1
9	VM117	Poly Float	1
10	VP224	Valve Assembly, 1/4" Orifice	1
11	OP223	3/4" Schedule 40 Plug, PVC	1
12	OP114	3/4" x 3/4" x 3/4" Schedule 80 Tee, PVC	1
13	OP116	3/4" Schedule 40 Male Adapter, Machined, PVC	1
14	OP117SJM	1 1/4" Slip Joint Nut	1
15	WPM212	3/4" PVC Pipe x 19-1/4" (Supply Tube)	1
16	WPM213	Riser Tube Assembly, 17 1/2"	1
17	OP119	1 3/4" ID x 2 1/8" OD "O" Ring, Rubber	1
18	OP116P	3/4" Schedule 40 Male Adapter, Standard, PVC	1
19	OP314	#11.5 Rubber Stopper	2
20	WPM200	Base Reservoir 20 Gal., Blue	1
20	MPM200	Base Reservoir 20 Gal., Red	1
21	OP210	1 1/2" NPT Pipe Plug, PVC	1
22	WT208	Foam Pipe Insulation 36"	1
23	OP93	10 1/2" Tywrap	1
24	WPM205	Flap, Cattle, Blue	1
24	MPM205	Flap, Cattle, Red	1
	WPM208	Hardware Bag	1

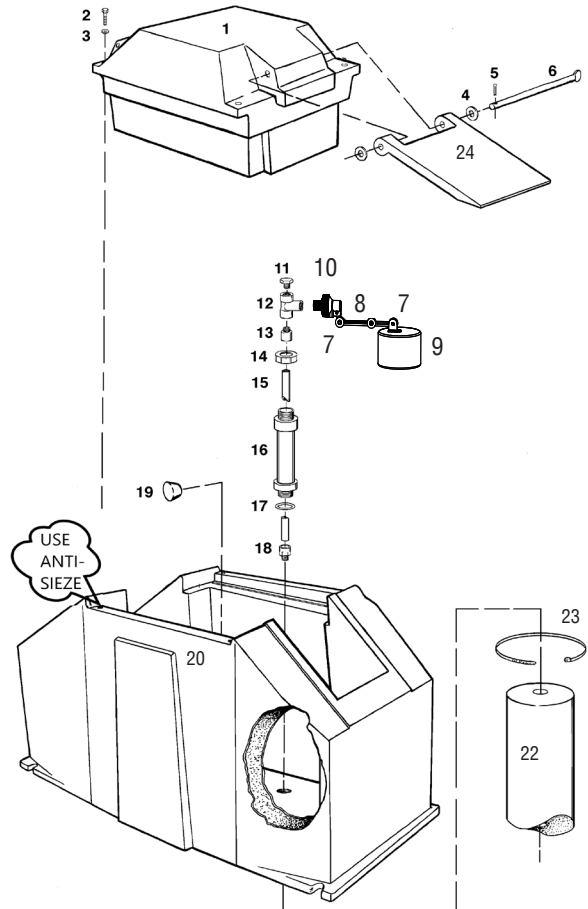

NOTE: Base dimensions of models are not the same. For example: WPM20 is longer than WPM10. Also, the threaded access for the riser tube assembly is not in the same location on all drinkers. Do not assume models are similar.

OUR VALVE IS MOLDED WITH ABS RESIN. FOR THREAD SEALING, USE ONLY STANDARD TEFLON TAPE OR PLASTIC COMPATIBLE TEFLON SEALANT. DO NOT USE PIPE THREAD SEALANT (COMMONLY CALLED "PIPE DOPE") OR SEALANT FORMULATED WITH PTFE.

Top Down View
Base Dimensions in Inches (Centimeters)

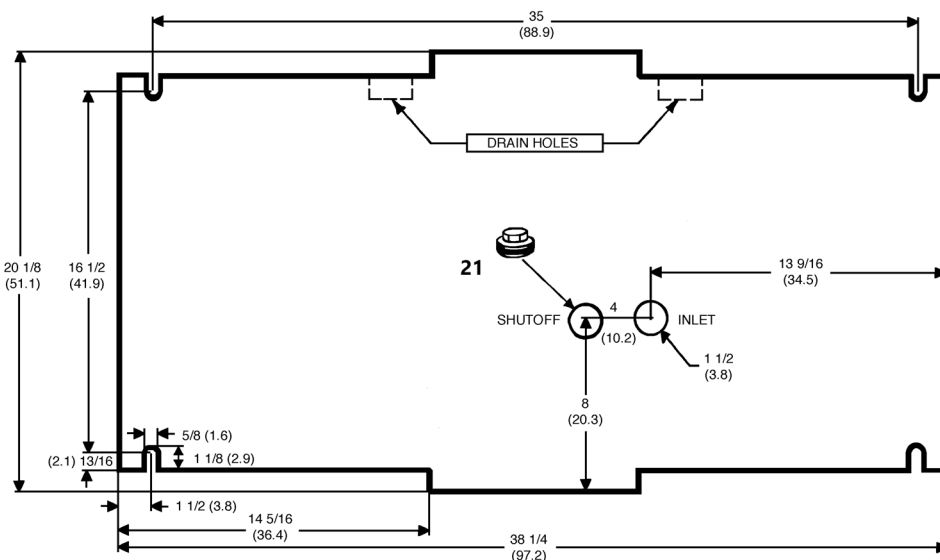

NOTE: Supply line hole in base is marked "INLET". Hole for shutoff option is marked "SHUTOFF". See Page 78

The dimensions shown are as accurate as we can show them. However, the molding process is affected by the temperature and humidity conditions on the day the part is molded. As the material cools, there can be uneven and unpredictable shrink which can affect the dimensions shown. It is usually best to wait until you have the actual drinker you are going to install before installing all four mounting studs.

Assembly Schematic, Repair Parts List, Base Dimensions

Model WPM80

Ref. No.	Part No.	Description	Qty
1	WPM7503	Cover, Blue	1
2	OF448	1/4-20 x 1 1/2 Indented Hex Head Machine Screw, SS	6
3	OF127SS	1.10" OD x .280" ID Washer, SS, 1"	6
4	OF351	3/8" ID x 7/8" OD Washer, SS - 5/16"	8
5	OF78SS	1/8 x 3/4 Cotter Pin, SS	4
6	WPM107	.311 x 13.187 Lid Hinge Rod, Zinc	4
7	VP115	Adjusting Screw	2
8	VA6	Float Arm, 6" Plastic	1
9	VM117	Poly Float	1
10	VP224	Valve Assembly, 1/4 Orifice	1
11	OP223	3/4" Schedule 40 Plug, PVC	1
12	OP114	3/4" x 3/4" x 3/4" Schedule 80 Tee, PVC	1
13	OP116	3/4" Schedule 40 Male Adapter, Machined, PVC	1
14	OP117SJM	1 1/4" Slip Joint Nut	1
15	WPM7512	3/4" PVC Pipe x 24 3/4" (Supply Tube)	1
16	WPM7513	Riser Tube Assembly, 21 1/2"	1
17	OP119	1 3/4" ID x 2 1/8" OD "O" Ring, Rubber	1
18	OP116P	3/4" Schedule 40 Male Adapter, Standard, PVC	1
19	OP314	#11.5 Rubber Stopper	2
20	WPM7500	Base Reservoir 80 Gal., Blue	1
21	OP210	1 1/2" NPT Pipe Plug, PVC	1
22	WT208	Foam Pipe Insulation 36"	1
23	OP93	10 1/2" Tywrap	1
24	WPM205	Flap, Cattle, Blue	4
25	WPM7519	Access Cover	1
	WPM1508	Hardware Bag	1

The dimensions shown are as accurate as we can show them. However, the molding process is affected by the temperature and humidity conditions on the day the part is molded. As the material cools, there can be uneven and unpredictable shrink which can affect the dimensions shown. It is usually best to wait until you have the actual drinker you are going to install before installing all four mounting studs. OUR VALVE IS MOLDED WITH ABS RESIN. FOR THREAD SEALING, USE ONLY STANDARD TEFLON TAPE OR PLASTIC COMPATIBLE TEFLON SEALANT. DO NOT USE PIPE THREAD SEALANT (COMMONLY CALLED "PIPE DOPE") OR SEALANT FORMULATED WITH PTFE.

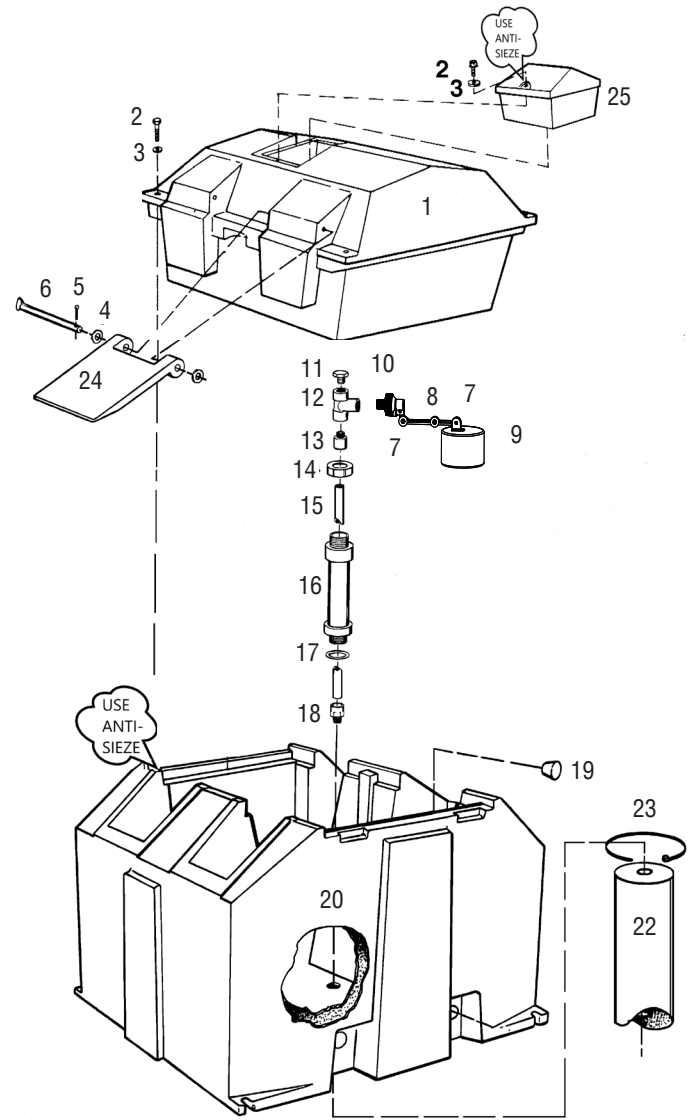

Top Down View
Base Dimensions in Inches
(Centimeters)

Connects to Ref. No. 18
Adapter thru hole marked
"INLET"

Insert thru hole marked
"SHUTOFF"

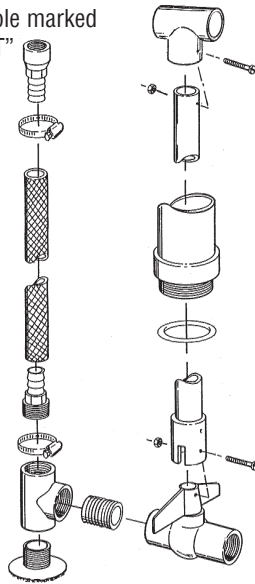

SOK10 SHUTOFF AND DRAIN
KIT OPTION

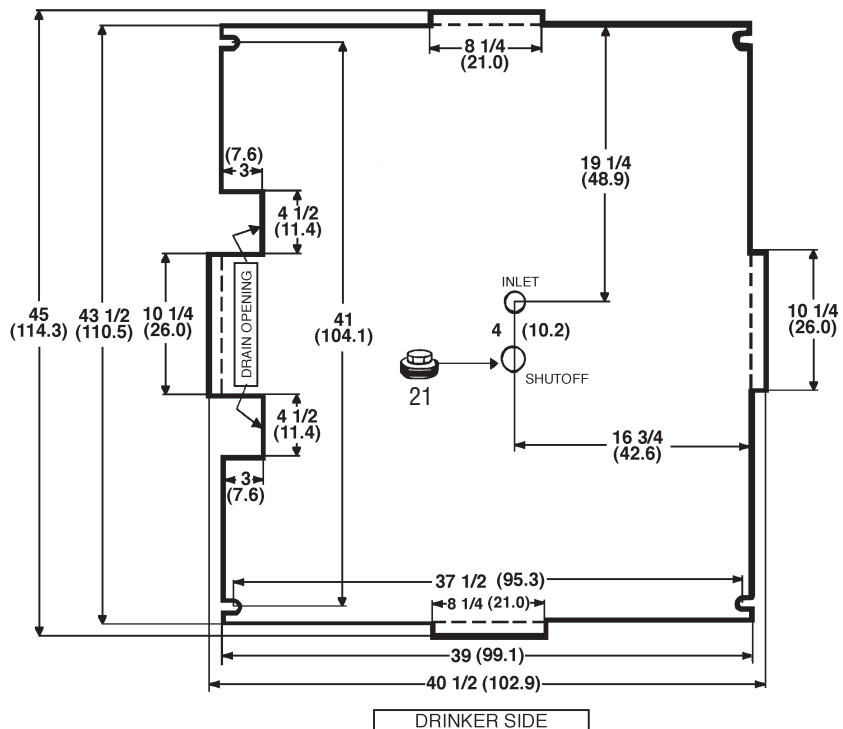

Assembly Schematic, Repair Parts List, Base Dimensions

Model WPM120 WPM120-O

Ref. No.	Part No.	Description	Qty
1	WPM1224	Cover, Blue	1
2	OF448	1/4"-20 x 1 1/2" Indented Hex head Machine Screw	2
3	OF127SS	1.10" OD x .280" ID Washer, SS, 1"	2
4	OF351	5/16" ID x 3/4" OD Washer, SS - 5/16" *	12
5	OF78SS	1/8" x 3/4" Cotter Pin, SS *	6
6	WPM107	.311 x 13.187 Lid Hinge Rod, Zinc *	6
7	VP115	Adjusting Screw	2
8	VM112	Float Arm, 6"	1
9	VM117	Poly Float	1
10	VM100	Valve Assembly, .45 Orifice, 3/4" Base	1
11	OP223	3/4" Schedule 40 Plug, PVC	1
12	OP114	3/4" x 3/4" x 3/4" Schedule 80 Tee, PVC	1
13	OP116	3/4" Schedule 40 Male Adapter, Machined, PVC	1
14	OP117SJM	1 1/4" Slip Joint Nut	1
15	WPM1207	3/4" PVC Pipe x 24" (Supply Tube)	1
16	WPM1208	Riser Tube Assembly, 20"	1
17	OP119	1 1/4" ID x 2 1/8" OD "O" Ring, Rubber	1
18	OP116P	3/4" Schedule 40 Male Adapter, Standard, PVC	1
19	OP299	3" Hole Plug	2
20	OP210	1 1/2" NPT Pipe Plug, PVC	1
21	OP342	3" NVF Plug, PVC	1
22	WPM1221	Base Reservoir 20 Gal., Red	1
23	WT208	Foam Pipe Insulation 36"	1
24	OP93	10 1/2" Tywrap	1
25	WPM205	Flap, Cattle, Blue *	6
26	WPM1226	Wiring Assembly *	2
27	WPM1211	Access Cover	1
	WPM1230	Hardware Bag	1

* Model WPM120-O does not include Ref. Nos. 4, 5, 6, 25, & 26

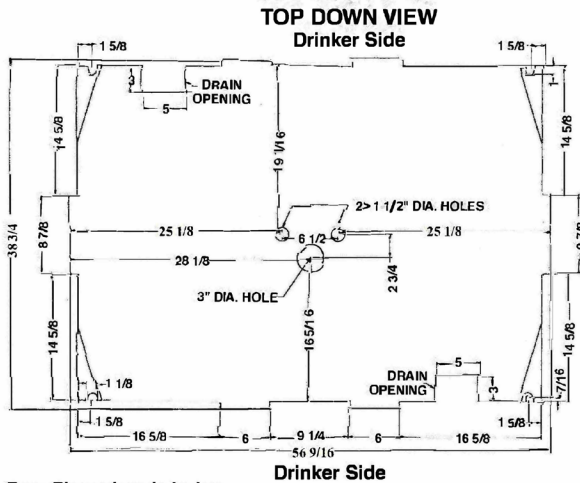

Base Dimensions in Inches

NOTE: The 2 - 1.5" Supply lines in the base are not labeled. You can use either hole for the Supply Line.

ACCESS PORT KIT OPTION
Pull Plug or Overflow
Model WPMAP10

Ref. No.	Part No.	Descri
28	WPM1232	3" X 21" Drain Pipe PVC
29	OP296	3" Male Adapter
30	OP297	3" O-Ring
31	WPM1233	3/4" X 6" Pipe Handle PVC

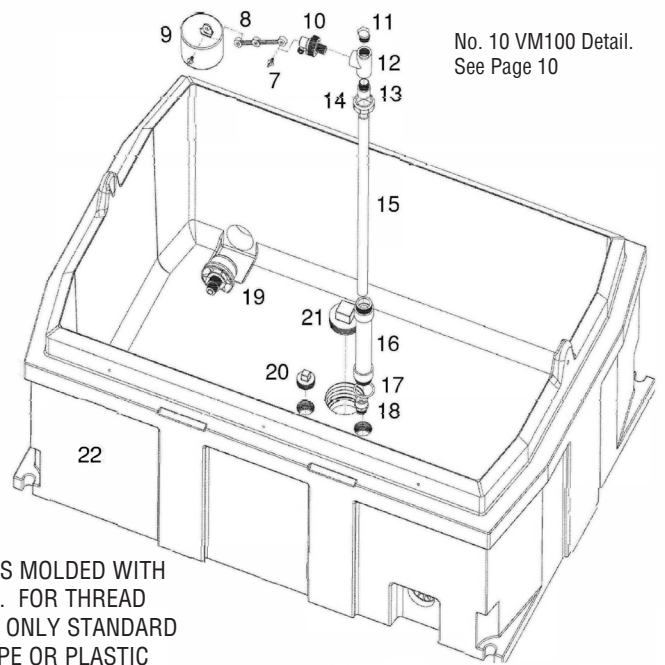
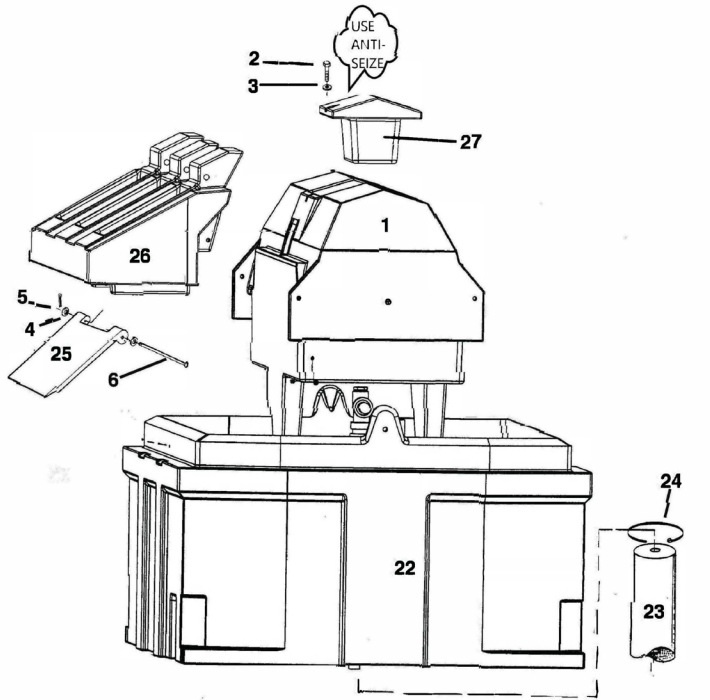

OUR VALVE IS MOLDED WITH ABS RESIN. FOR THREAD SEALING, USE ONLY STANDARD TEFLON TAPE OR PLASTIC COMPATIBLE TEFLON SEALANT. DO NOT USE PIPE THREAD SEALANT (COMMONLY CALLED "PIPE DOPE") OR SEALANT FORMULATED WITH PTFE.

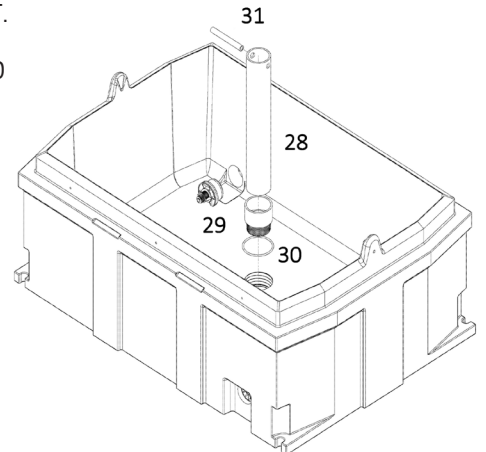

Monticello Valve Model VM100

Used in Models WPM120 and WPM120-0 Drinkers

(Other drinkers in this instruction book use VP224)

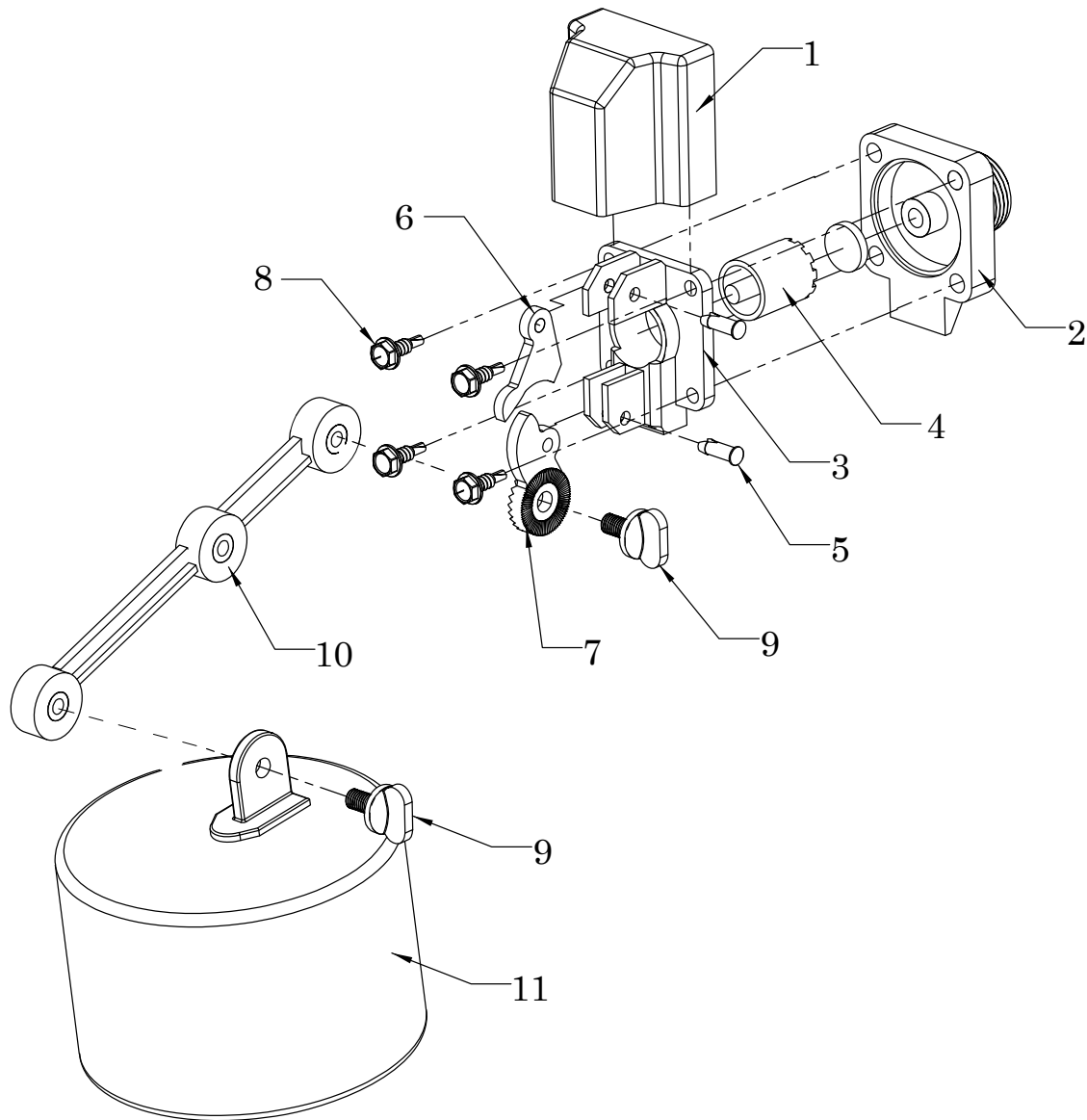

Monticello Valve Parts

Ref. No.	Model Number	Description
1	VM101	Cap, Poly, BL101
2	VM102	3/4" Base, .45" Orifice, Poly, BL102
3	VM105	Top Base, Poly, BL105
4	VM103	Plunger w/Seat, Poly, BL108
5	VM106	Lock Pin, Poly, BL106
6	VM110	Upper Arm, Poly, BL110
7	VM111	Lower Arm, Poly, BL111
8	OF210	#10 x 5/8" HWS Screw, BL109
9	VP115	Thumb Screw, Poly, BL114
10	VM112	Float Arm, Poly w/ Brass Nuts, BL112
11	VM117	4 3/4" x 3" Float, Poly, BL117P

NOTE ABOUT COVER VENT HOLES

Our energy free drinkers have 4 vent holes in the valve chamber of the top cover. In normal operations, when animals drink down the water, the valve starts to re-fill the drinker. As the water level starts to rise to the re-fill line, air then becomes trapped inside the valve chamber. This compressed air then exhausts through the 4 vent holes allowing the water level to rise and then the float will shut off the valve. When the water level drops, outside air comes in to relieve the vacuum that is created.

During rare extreme cold weather spells, the damp air being pushed out through the vent holes will encounter frigid outside air. Frost and icing can form on the outside of the vent hole especially if there is other debris build up in the holes such as from spiders and other insects. When the vent holes frost over, air cannot escape and the drinker will start overflowing. This occurrence is very rare. The quickest solution is to remove the top cover and locate the vent holes. Use a screwdriver, 1/4" drill bit or heavy gauge wire to open the holes.

On Models WPM10/MPM10; WPM10A/MPM10A; WPM14; WPM16; WPM20/MPM20, there are four holes in the corners of the valve cover as shown below.

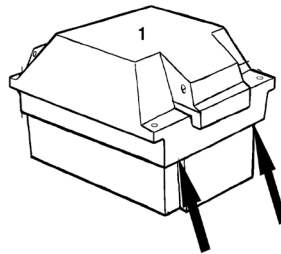
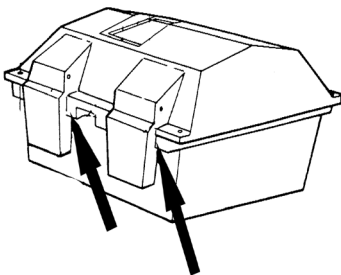

Hole location, Model WPM80

On Model WPM80, you can try this first. Remove the access cover (Ref No. 25 on page 8). If the access cover is iced in, remove the ice, re-install the cover and most likely your valve will operate. If the valve operates after access cover removal and then fails to operate again, you should clean out the vent holes.

There are no vent holes on Model WPM120. Again, remove the access cover (Ref No. 27 on page 9). Remove any ice and your valve should operate.

THIS PAGE IS INTENTIONALLY LEFT BLANK